

Current Sensors & Monitors

Selection Guide 8.2

Over or Under Current

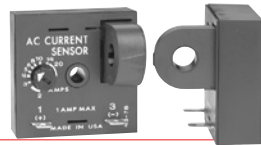

- ECS 8.4
- TCS 8.8

Over and Under Current Monitor



- ECSW 8.6

Current Transducer



- TCSA 8.10
- DCSA 8.12

Current Indicator



- LCS 8.14
- LPM 8.14

DIN Rail Mounting Current Monitors



- CM-SFS
- CM-SRS.1
- CM-SRS.2
- CM-SRS.M

Note:
 Product pages are not included in this catalog. Go to:
www.ssac.com/s8.pdf. Click on the Product Name (ie: CM-SRS.1) to open the catalog page.
 [Adobe Acrobat Reader is required]

DIN Rail Mounting Motor Load Monitors



- CM-LWN See Note above
- DIN Rail Mounting Load Monitor Application Page See Note above

Selection Guide Current Monitoring

Sensing/Control Relays

Analog Output

For detailed product specifications, refer to catalog pages.



Adjustable, AC over & undercurrent trip points w/selectable response modes.



Selectable AC over or undercurrent; adjustable trip point & delay.



Low cost AC current switch; direct connection to digital PLC input; sinking or sourcing.

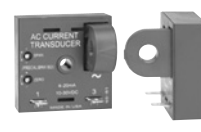

Current transducer; linear output proportional to the RMS AC current.





Current transducer; linear output proportional to the RMS AC current.

Functions and Features	Series Page	ECSW 8.6	ECS 8.4	TCS 8.8	TCSA 8.10	DCSA 8.12
General Features						
DIN Rail Mounting				w/adaptor	w/adaptor	•
Surface Mounting		•	•	•	•	w/adaptor
Screw Terminals		•				•
Quick Connects			•	•	•	
Output						
Linear 4 to 20 mA					•	•
SPDT Relay		•	•			
1 A Solid State				•		
Monitored Current						
AC		•	•	•	•	•
DC						
Input or Output Voltage						
24 VAC		•	•			
24 ... 240 V AC				Self-Powered		
110 ... 130 V AC		•	•			
220 ... 240 V AC		•	•			
12 & 24 V DC		•	•		Loop Powered	Loop Powered
3 ... 50 V DC				Self-Powered		
Trip Range(s)						
Fixed				•		
Adjustable		•	•	•	•	•
3 mA ... 1 A						
2 ... 45 A fixed / 2... 20 adjustable				•		
0 ... 50 A				•	•	•
0.5 ... 50 A		•	•			
Delay(s)						
Trip Delay		•	•			
Start up Delay		•	•			
Indicator LED(s)						
Output ON/OFF		•				
Supply ON/OFF						
Fault(s)		•	•			
Timing		•				
Dimensions	in mm	2.50 x 3.50 x 1.75 63.5 x 88.9 x 44.5		2.0 x 2.0 x 1.75 50.8 x 50.8 x 44.5		0.71 x 2.44 x 2.56 18 x 62 x 65

Selection Guide

Current Monitoring

Current
Sensors &
Monitors

	Current Indicator	AC/DC Current Sensors			Motor Load Monitor
For detailed product specifications, refer to catalog pages.	 Monitor AC current flow with visual indication up to 500 feet from source.	 AC/DC version w/selectable over or undercurrent; relay output.	Fully adjustable Window Current Sensing, selectable normally energized or de-energized relay outputs: latching or not.		 2 Relay outputs; monitors under & over loading.
Series	LCS/LPM	CM-SRS.1	CM-SRS.M	CM-SFS	CM-LWN
Page	8.14	CM-SRS.2	Product pages available at www.ssac.com/sg8.pdf		
Functions and Features					
General Features					
DIN Rail Mounting		•	•	•	•
Surface Mounting		w/adaptor	w/adaptor	w/adaptor	w/adaptor
Screw Terminals		•	•	•	•
Quick Connects					
Wire Leads	•				
Output					
DPDT Relay (2 SPDT)		CM-SRS.2	•	•	•
SPDT Relay		CM-SRS.1			
Latching Output			•	•	
Analog	•				
Monitored Current					
AC	•	•	•	•	•
DC		•	•	•	
Supply Voltage					
24 VAC					
24 ... 240 V AC/DC		•	•	•	•
42 ... 48 V AC					
110 ... 130 V AC		•			•
220 ... 240 V AC		•			•
380 ... 415 V AC					•
480 ... 500 V AC					•
Trip Range(s)					
Fixed	•				
Adjustable		•	•	•	•
3 mA ... 1 A		•	•	•	
300 mA ... 15 A		•	•	•	
0.5 ... 20 A					•
0.5 ... 50 A	•				
Hysteresis Adjustable		•	•	•	
Delay(s)					
Trip		CM-SRS.2	•	•	•
Inrush			•	•	•
Indicator LED(s)					
Output ON/OFF		•	•	•	•
Supply ON/OFF		•	•	•	•
Fault(s)		•	•	•	•
Timing		•	•	•	
Dimensions	in	0.98 x 1.51 x 0.46	0.886 x 3.07 x ≤ 3.98		1.77 x 3.07 x ≤ 3.98
	mm	24.89 x 38.35 x 11.68	22.5 x 78 x ≤ 101		45 x 78 x ≤ 101

08021 10.27.06

Over/Under Current Sensing ECS Series Current Sensor



- Toroidal Through Hole Wiring
- 0.5...50 A Trip Point
- Adjustable or Factory Fixed Trip Delays
- 10 A SPDT Isolated Output Contacts
- 5% Trip Point Hysteresis (Dead Band)

Approvals:

Description

The ECS Series of Single Phase AC Current Sensors is a universal, overcurrent or undercurrent sensing control. Its built-in toroidal sensor eliminates the inconvenience of installing a stand-alone current transformer. Includes onboard adjustments for current sensing mode, trip point, and trip delay. Detects over or under current events like locked rotor, loss of load, an open heater or lamp load, or proves an operation is taking place or has ended.

Operation

Input voltage must be supplied at all times for proper operation. When a fault is sensed throughout the trip delay, the output relay is energized. When the current returns to the normal run condition, the output and the delay are reset. If a fault is sensed and then corrected before the trip delay is completed, the relay will not energize and the trip delay is reset to zero.

Adjustment

Select the desired function, over or under current sensing. Set the trip point and trip delay to approximate settings. Apply power to the ECS and the monitored load. Turn adjustment and watch the LED. LED will light; turn slightly in opposite direction until LED is off. Adjustment can be done while connected to the control circuitry if the trip delay is set at maximum.

Connection

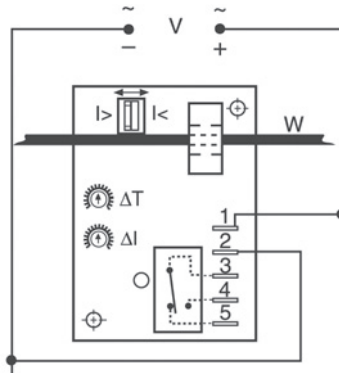

Relay contacts are isolated.
Dashed lines are internal connections.

V = Voltage I> = Overcurrent I< = Undercurrent
W = Insulated Wire Carrying Monitored Current

Function

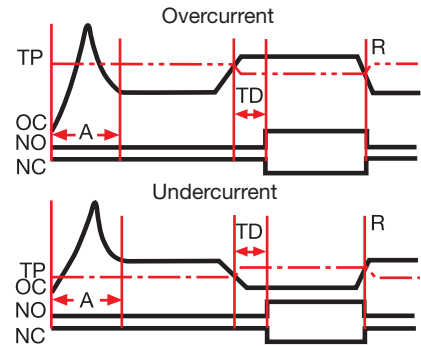

TP = Trip Point R = Reset OC = Monitored Current
NO = Normally Open Contact NC = Normally Closed Contact
A = Sensing Delay On Start Up TD = Trip Delay

Ordering Table

X Series	X Input	X Trip Point	X Trip Delay	X Sensing Delay on Start up
ECS - (selectable over or under current sensing)	-1 - 12 V DC	Fixed - Specify 2 ... 50 A in 1 A increments	-F - Factory Fixed: Specify .08 ... 50 s	Blank - 0 s
ECSH - (overcurrent sensing)	-2 - 24 V AC	Adjustable Ranges -0 - 0.5 ... 5 A -1 - 2 ... 20 A -H - 5 ... 50 A	Adjustable Ranges -A - 0.150 ... 7 s -B - 0.5 ... 50 s	C - 1 s
ECSL - (undercurrent sensing)	-3 - 24 V DC			D - 2 s
	-4 - 120 V AC			E - 3 s
	-6 - 230 V AC			F - 4 s
				G - 5 s
				H - 6 s

Example P/N: **ECS41AC** Fixed - **ECSH610AD**

Accessories



Female quick connect P/Ns:

- P1015-13** (AWG 10/12)
- P1015-64** (AWG 14/16)
- P1015-14** (AWG 18/22)

See accessory pages for specifications.

Over/Under Current Sensing

ECS Series

Current Sensor

Current
Sensors &
Monitors

Technical Data

Sensor		
Type		Toroidal, through hole wiring
Mode		Over or under current, switch selectable on the unit or factory fixed
Trip Point Range		0.5 ... 50 A in 3 adjustable ranges or fixed
Tolerance:	Adjustable	Guaranteed range
	Fixed	0.5 ... 25 A: 0.5 A or +/-5% whichever is less; 26 ... 50 A: +/-2.5%
Maximum Allowable Current		Steady – 50 A turns; Inrush – 300 A turns for 10 s
Trip Point Hysteresis		≅ +/-5%
Trip Point vs. Temperature		+/-5%
Response Time		≤ 75 ms
Frequency		45 ... 500 Hz
Type of Detection		Peak detection
Trip Delay		
Type		Analog
Range:	Adjustable	0.150 ... 7 s; 0.5 ... 50 s (Guaranteed ranges)
	Factory Fixed	0.08 ... 50 s (+/-10%)
Delay vs. Temperature		+/-15%
Sensing Delay on Startup		Factory fixed 0 ... 6 s: +40% ... 0%
Input		
Voltage		24 , 120, or 230 V AC; 12 or 24 V DC
Tolerance	12 V DC & 24 V DC/AC	-15% ... +20%
	120 & 230 V AC	-20% ... +10%
Line Frequency		50 ... 60 Hz
Output		
Type		Electromechanical relay
Form		Isolated single pole double throw (SPDT)
Rating		10 A resistive at 240 V AC; 1/4 hp at 125 V AC; 1/2 hp at 250 V AC
Life		Mechanical – 1 x 10 ⁶ ; Electrical – 1 x 10 ⁵
Protection		
Circuitry		Encapsulated
Isolation Voltage		≥ 2500 V RMS input to output
Insulation Resistance		≥ 100 MΩ
Mechanical		
Mounting		Surface mount with two #6 (M3.5 x 0.6) screws
Termination		0.25 in. (6.35 mm) male quick connect terminals (5)
Humidity		95% relative, non-condensing
Operating/Storage Temperature		-40°C ... +60°C / -40°C ... +85°C
Weight		≅ 6.4 oz (181 g)

8

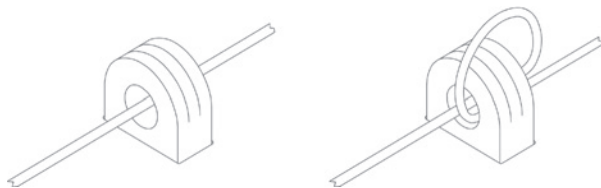

Multiple Turns To Increase Sensitivity

To increase sensitivity, multiple turns may be made through the ECS's toroidal sensor. The trip point range is divided by the number of turns through the toroidal sensor to create a new range.

Using an External Current Transformer (CT)

Select a 2 VA, 0 to 5 A output CT, rated for the current to be monitored. Select ECS adjustment range 0. Pass the CT's secondary wire lead through the ECS's toroid and connect both ends together.

Mechanical View

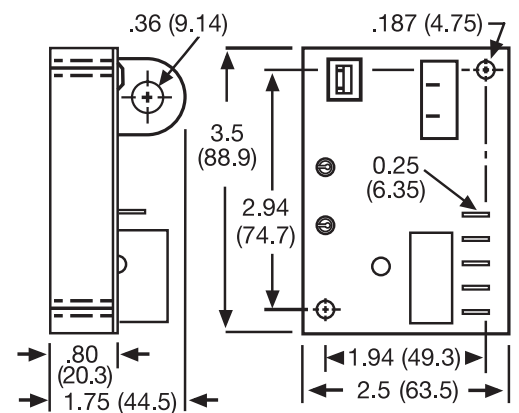

Inches (Millimeters)

Window Current Sensor

ECSW Series

Current Sensor



- Overcurrent & Undercurrent (Window Current) Sensing
- Adjustable Overcurrent & Undercurrent Trip Points
- Current Sensor is Included
- 10 A SPDT Isolated Output Contacts
- LED Indicators

Approvals:

Selector Switch

ON ↔ OFF

- | | | |
|-----|--------------------------|--------------------|
| SW1 | <input type="checkbox"/> | Not Used |
| SW2 | <input type="checkbox"/> | Latched |
| SW3 | <input type="checkbox"/> | Zero I |
| | <input type="checkbox"/> | Output |
| | <input type="checkbox"/> | Normally Energized |

Mode Selection Switches

- SW1 = Latched or Auto reset selector
 OFF - Automatic reset after a fault
 ON - Output relay latches after a fault trips the unit
- SW2 = Zero current detection - (below 250 mA)
 OFF- Zero current detection disabled
 ON- Zero current detection enabled
- SW3 = Output during normal operation
 OFF- Output relay de-energized
 ON - Output relay energized

Description

The ECSW Series of single phase, AC window current sensors includes adjustable overcurrent and undercurrent trip points. Detects locked rotor, a jam, loss of load, an open heater or lamp load, a broken belt, or loss of suction. LED's aid in trip point adjustment and provide fault indication. The built-in toroidal sensor eliminates the need for an external current transformer. The output can be electrically latched after a fault, or automatically reset. Remote resetting of a latched output by removing input voltage. The unit includes switch selectable zero current detection and normally de-energized or energized output operation. Time delays are included to improve operation and eliminate nuisance tripping.

Operation

When the input voltage is applied, sensing delay on startup begins and the output transfers (if normally energized is selected). Upon completion of the startup delay, sensing of the monitored current begins. As long as current is above undercurrent trip point and below the overcurrent trip point (inside the window), the output relay remains in its normal operating condition and both red LED's are OFF. The green LED glows when the output is energized. If current varies outside the window, the associated red LED glows, and the trip delay begins. If the current remains outside the window for the full trip delay, the relay transfers to fault condition state. If the current returns to normal levels (inside the window) during the trip delay, the red LED goes OFF, the trip delay is reset, and the output remains in the normal condition.

Reset: Remove input voltage or open latch switch. If zero current detection is selected, the unit will reset as soon as zero current is detected.

Operation With Zero Current Detection Enabled: If the current decreases to zero within the trip delay period, then zero current is viewed as an acceptable current level. The unit's output remains in its normal operating state. This allows the monitored load to cycle ON and OFF without nuisance tripping the ECSW. Zero current is defined as current flow of less than 250 milliamp-turns. Note: When zero current detect is selected, the latching operation of switch SW2 is canceled; the output will not latch after a fault trip.

Notes on Operation:

- 1) There is no hysteresis on the trip points. The overcurrent and undercurrent trip points should be adjusted to provide adequate protection against short cycling.
- 2) If the upper set point is set below the lower set point, both red LED's will glow indicating a setting error.
- 3) If zero current detection is selected (SW2 ON), and the system is wired to disconnect the monitored load, the system may short cycle. After the unit trips, the load de-energizes, and zero current is detected. The ECSW resets, and the load energizes again immediately and may be short cycled.
- 4) The sensing delay on start up only occurs when input voltage is applied. When zero current detection is selected, the trip delay must be longer than the duration of the inrush current or the unit will trip on the inrush current.

Typical Pump or Fan Protection Circuit Operation

Window Current Sensing: With the ECSW connected as shown in the diagram, a load may be monitored and controlled for over and under current. The ECSW Series' on board CT (CS) may be placed on the line or load side of the contactor. The ECSW selection switches are set for zero current sensing (see Selector Switch SW2) and the output selection is normally de-energized (see Selector Switch SW3). The input voltage (V) is applied to the ECSW continually. As the control switch (FSW) is closed, the input voltage (V) is applied to the motor contactor coil (MCC), and the motor (M) energizes. As long as the current remains below the overcurrent and above the undercurrent trip points, the ECSW's output contacts remain de-energized. If the load current should rise above or fall below a trip point, for the full trip delay, the normally open (NO) contact will close, energizing the control relay (CR) coil. The CR normally closed contact (CR1) opens and the MCC de-energizes and CR latches on through its normally open contacts (CR2). Reset is accomplished by momentarily opening the normally closed reset switch (RSW).

Connection

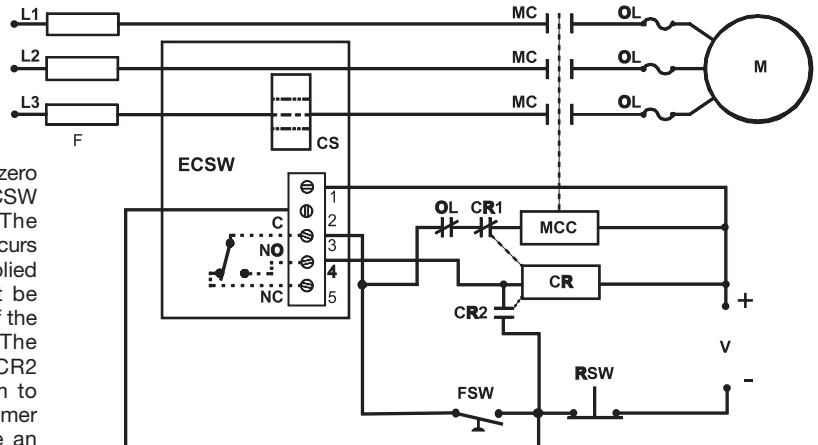

MC = Motor Contactor M = Motor F = Fuses
 OL = Overload RSW = Reset Switch
 FSW = Fan or Float Switch CR = Control Relay
 CS = Current Sensor MCC = Motor Contactor Coil

Note: The output is normally de-energized.

Window Current Sensor

ECSW Series

Current Sensor

Current
Sensors &
Monitors

Technical Data

Sensor		
Type		Toroid, through hole wiring for up to #4 AWG (21.1 mm ²) THHN wire
Mode		Over and under current trip points (window current sensing)
Trip Point Range		0.5 ... 50 A in 3 adjustable ranges
Tolerance		Guaranteed range
Maximum Allowable Current		Steady - 50 A turns; Inrush - 300 A turns for 10 s
Trip Point vs. Temperature & Voltage		+/-5%
Response Time		≤ 75 ms
Frequency		45 ... 500 Hz
Type of Detection		Peak detection
Zero Current Detection		< 250 mA turns typical
Time Delay		
Range		0.15 ... 50 s in 2 adjustable ranges or 0.08 ... 50 s fixed
Tolerance		Adjustable: guaranteed range; Fixed: +/-10%
Sensing Delay On Start Up		Fixed ≅ 0.1 ... 6 s in 1 s increments
Tolerance		+40% -0%
Delay vs. Temperature & Voltage		+/-15%
Input		
Voltage		24, 120, or 230 V AC; 12 or 24 V DC
Tolerance	12 V DC & 24 V DC/AC	-15% ... +20%
	120 & 230 V AC	-20% ... +10%
AC Line Frequency		50 ... 60 Hz
Output		
Type		Electromechanical relay
Mode: Switch selectable	ON - OFF -	Energized during normal operation, de-energized after a fault De-energized during normal operation, energizes during a fault
Form		Isolated, SPDT
Rating		10 A resistive at 240 V AC; 1/4 hp at 125 V AC; 1/2 hp at 250 V AC
Life		Mechanical: 1 x 10 ⁶ ; Electrical: 1 x 10 ⁵
Latch	Type Reset Function	Electrical Remove input voltage Switch selectable latching function
Protection		
Surge		IEEE C62.41-1991 Level A
Circuitry		Encapsulated
Isolation Voltage		≥ 2500 V RMS input to output
Insulation Resistance		≥ 100 MΩ
Mechanical		
Mounting		Surface mount with two #6 (M3.5 x 0.6) screws
Termination		0.197 in. (5 mm) terminal blocks for up to #12 (3.2 mm ²) AWG wire
Environmental		
Operating Temperature		-40° C ... +60° C
Storage Temperature		-40° C ... +85° C
Humidity		95% relative, non-condensing
Weight		≅ 6.4 oz (181 g)

Connection

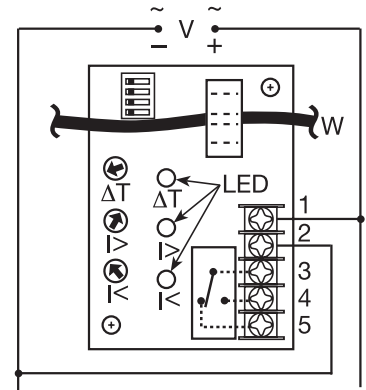

V = Voltage W = Monitored Wire
 ΔT = Adjustable Trip Delay
 $>$ = Adjustable Overcurrent
 $<$ = Adjustable Undercurrent

Mechanical View

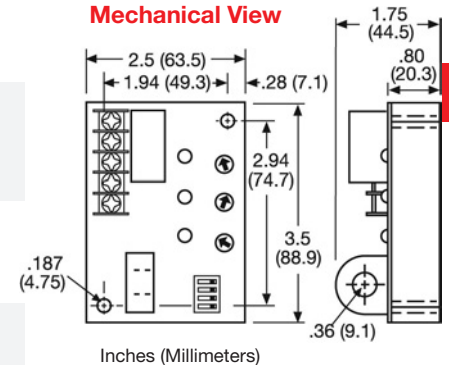

Ordering Table

ECSW	X	X	X	X	X
Series	Input	Trip Point Range Adjustable Ranges	Trip Delay	Sensing Delay on Start Up	Connection
	-1 - 12 V DC	-L - 0.5 ... 5 A	-A - Adjustable 0.15 ... 7 s	-B - 0.1 s	-T - Terminal Blocks
	-2 - 24 V AC	-M - 2 ... 20 A	-B - Adjustable 0.5 ... 50 s	-C - 1 s	
	-3 - 24 V DC	-H - 5 ... 50 A	-F - Fixed*	-D - 2 s	
	-4 - 120 V AC			-E - 3 s	
	-6 - 230 V AC			-F - 4 s	
				-G - 5 s	
				-H - 6 s	

Example P/N: **ECSW4LBCT** Fixed - **ECSW4HF10DT**

*If Fixed Delay is selected, insert delay
[0.08 ... 50] in seconds. 0.1 ... 2 s in 0.1 s
increments; 2 ... 50 s in 1 s increments

AC Current Sensor, PLC Interface Module

TCS Series

Current Sensor

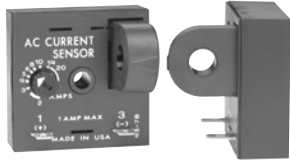

- Direct Connection to a PLC Digital Input Module
- 3 ... 50 V DC, 24 ... 240 V AC in 2 Ranges
- 1 A Steady - 10 A Inrush
- Actuation Points –
2 ... 45 A (Fixed Units)
2 ... 20 A (Adjustable Units)
- Normally Open or Closed Solid State Output
- Complete Isolation Between Sensed Current & Control Circuit

Approvals:

8

Accessories

Female quick connect
P/N: **P1015-64** (AWG 14/16)

Quick connect to screw adaptor
P/N: **P1015-18**

Mounting bracket
P/N: **P1023-6**

DIN rail P/Ns:
017322005 (Steel)
C103PM (Al)
DIN rail adaptor
P/N: **P1023-20**

See accessory pages for specifications.

Description

The TCS Series is a low cost method of GO/NO GO current detection. It includes a solid state output to sink or source current when connected directly to a standard PLC digital input module. Its normally open or normally closed output can also be used to control relays, lamps, valves, and small heaters rated up to 1 A steady, 10 A inrush. The TCS is self-powered (no external power required to operate the unit) available with an adjustable actuation range of 2 to 20 A or factory fixed actuation points from 2 to 45 A.

Operation

Normally Open: When a current equal to or greater than the actuate current is passed through the toroidal sensor, the output closes. When the current is reduced to 95% of the actuate current or less, the output opens.

Normally Closed: When the current through the toroid is equal to or greater than the actuate current, the output opens. When the current is reduced below 95% of the actuate current, the output closes.

Function

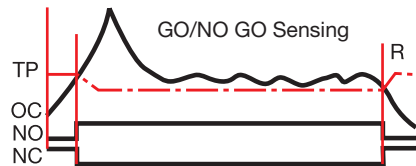

L = Load V = Voltage PS = Power Supply
PLC = PLC Digital Input Module R = Reset
TP = Trip Point OC = Monitored Current
NO = Normally Open Output
NC = Normally Closed Output

Connection

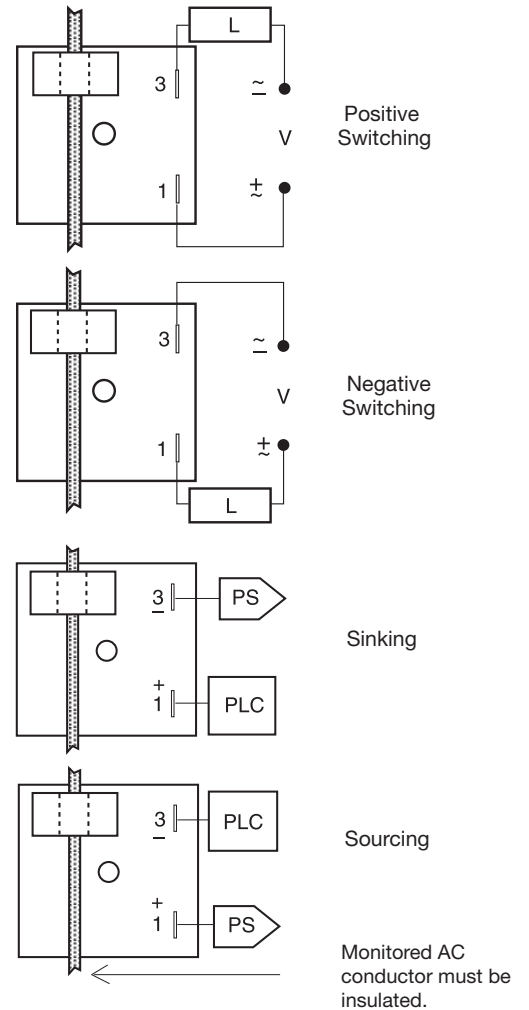

Ordering Table

TCS Series	X Output Voltage	X Actuate Current	X Output Form
	-G - 3 ... 50 V DC	-A - Adjustable 2 ... 20 A	-A - Normally Open
	-H - 24 ... 240 V AC	-Specify Fixed - Actuate Point 2 ... 45 A in 1 A increments	-B - Normally Closed

Example P/N: **TCSGAA** Fixed – **TCSH20A**

AC Current Sensor, PLC Interface Module

TCS Series

Current Sensor

Current
Sensors &
Monitors

Technical Data

Sensor Type Current to Actuate Reset Current Maximum Allowable Current Actuate Current vs. Temperature & Voltage Response Times Burden	Toroid, through hole wiring, alternating current, monitored wire must be properly insulated Adjustable Units -- 2 ... 20 A, Guaranteed Range Fixed Units -- 2 ... 45 A, +0/-20% \cong 95% of the actuate current Steady -- 50 A-turns Inrush -- 300 A-turns for 10 s \leq +/-5% Overcurrent -- \leq 200 ms Undercurrent -- \leq 1 s $<$ 0.5 VA
Output Type Form Rating Voltage Voltage Drop	Solid State Normally Open or Normally Closed 1 A steady, 10 A inrush AC -- 24 ... 240 V AC +10/-20% DC -- 3 ... 50 V DC AC N.O. & N.C. -- \cong 2.5 V DC N.O. & N.C. -- \cong 1.2 V
Protection Circuitry Dielectric Breakdown Insulation Resistance	Encapsulated \geq 2000 V RMS terminals to mounting surface \geq 100 M Ω
Mechanical Mounting Package Termination Sensor Hole	Surface mount with one #10 (M5 x 0.8) screw 2 x 2 x 1.75 in. (50.8 x 50.8 x 44.5 mm) 0.25 in. (6.35 mm) male quick connect terminals (2) 0.36 in. (9.14 mm) for up to #4 AWG (21.1 mm ²) THHN wire
Environmental Operating/Storage Temperature Humidity Weight	-20°C ... +60°C / -40°C ... +85°C 95% relative, non-condensing \cong 2.6 oz (74 g)

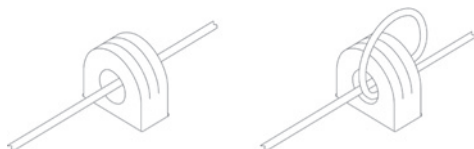

Multiple Turns To Increase Sensitivity

To increase sensitivity, multiple turns may be made through the TCS's toroidal sensor. The trip point range is divided by the number of turns through the toroidal sensor to create a new range.

Using an External Current Transformer (CT)

Select a 2 VA, 0 to 20 A output CT, rated for the current to be monitored. Pass one of the CT's secondary wire leads through the TCS's toroid. Connect the CT's secondary leads together.

Mechanical View

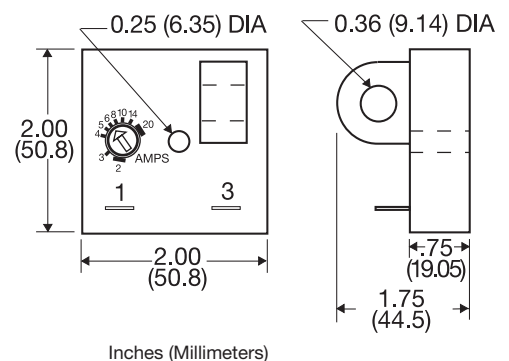

AC Current Transducer

TCSA Series

Loop Powered



- Monitors 0 ...50 A in 4 Ranges
- Loop Powered from 10 ... 30 V DC
- Linear Output from 4 ... 20 mA
- Zero and Span Adjustments
- Complete Isolation Between Sensed Current and Control Circuit

Approvals:

Description

The TCSA Series is a loop powered, linear output current transducer that provides an output that is directly proportional to the RMS AC current passing through the onboard toroid. The TCSA provides a 4 to 20 mA output over a power supply range of 10 to 30 V DC. Each unit is factory calibrated for monitoring from 0 to 5, 0 to 10, 0 to 20, or 0 to 50 A in four ranges. The 0 to 5 A range allows the use of external current transformers so loads up to 1200 AC amps can be monitored.

Operation

The TCSA varies the effective resistance of its output in direct proportion to the current flowing in the monitored conductor. The unit is factory calibrated so that 0 amps provides a 4 mA output and full span provides a 20 mA output. Zero and span adjustments are provided for minor calibration adjustments in the field (if required).

Using an External Current Transformer (CT)

Select a 2 VA, 0 to 5 A output CT, rated for the current to be monitored. Select TCSA5. Pass one of the CT's secondary wire leads through the TCSA's toroid. Connect the CT's secondary leads together.

Connection

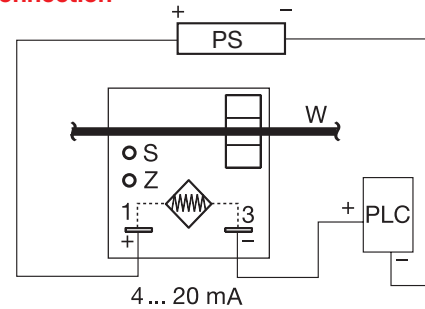

PS = Power Supply Z = Zero Adjust S = Span Adjust
W = Insulated Wire Carrying Monitored Current
PLC = PLC Analog Input or Meter Input

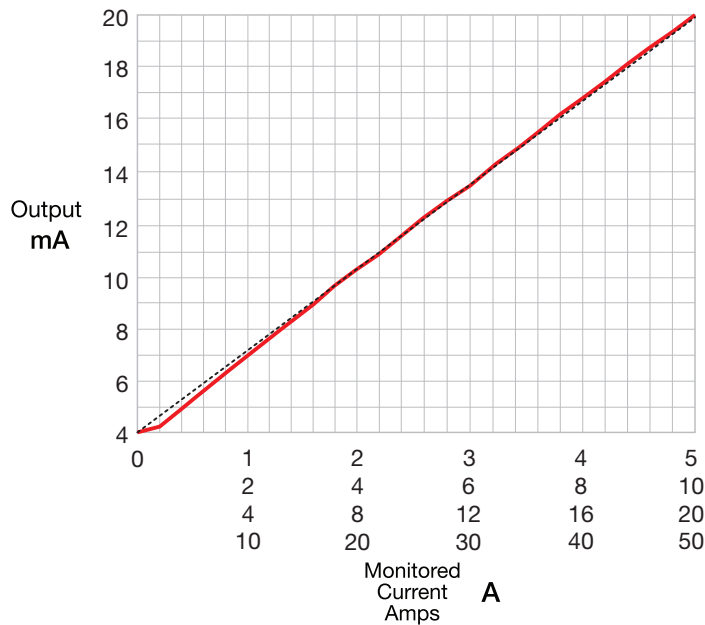

Accessories



Female quick connect P/N: **P1015-64** (AWG 14/16)

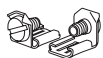

Quick connect to screw adaptor P/N: **P1015-18**



Mounting bracket P/N: **P1023-6**

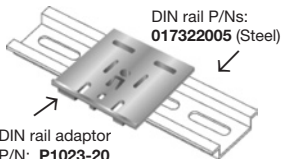

DIN rail adaptor P/N: **P1023-20**

See accessory pages for specifications.

Ordering Table

Current Range	Part Number
0 ... 5 A	TCSA5
0 ... 10 A	TCSA10
0 ... 20 A	TCSA20
0 ... 50 A	TCSA50

AC Current Transducer

TCSA Series

Loop Powered

Current
Sensors &
Monitors

Technical Data

Sensor	
Type	Toroid, through hole wiring, alternating current (Monitored conductor must be properly insulated)
Monitored AC Current Ranges	0 ... 50 A
4 factory calibrated ranges Factory Calibration	0 ... 5A, 0 ... 10A, 0 ... 20A, or 0 ... 50A
Maximum Allowable Current	≤±2% of full scale Steady – 50 A turns Inrush – 300 A turns for 10 s
Repeat Accuracy	≤±0.25% of full scale under fixed conditions
Response Time	≅ 300 ms
Burden	≤ 0.5 VA
Frequency	20 ... 100 Hz / 30 ... 100 Hz
Temperature Coefficient	+/-0.05%/°C
Output	
Type: Series Connection	Current directly proportional to monitored current
Range	4 ... 20 mA
Sensor Supply Voltage*	10 ... 30 V DC
Momentary Voltage	40 V DC for 1 m
Zero Adjust	≅ 3.75 ... 4.25 mA
Span Adjust	18 mA ... 22 mA
Adjustment	Mini-screw, 25 turn potentiometer
Protection	
Dielectric Breakdown	≥ 2000 V RMS terminals to mounting surface
Insulation Resistance	≥ 100 MΩ
Polarity	Units are reverse polarity protected
Mechanical	
Mounting	Surface mount with one #10 (M5 x 0.8) screw
Package	2 x 2 x 1.75 in. (50.8 x 50.8 x 44.5 mm)
Termination	0.25 in. (6.35 mm) male quick connect terminals
Sensor Hole	0.36 in. (9.14 mm) for up to #4 AWG (21.1 mm ²) THHN wire
Environmental	
Operating Temperature	-30°C ... +60°C
Storage Temperature	-40°C ... +85°C
Humidity	95% relative, non-condensing
Weight	≅ 2.4 oz (68 g)

*Minimum loop power supply voltage equals the minimum sensor voltage 10 V DC plus the voltage drop developed across all the other loop devices at 20 mA.

8

Mechanical View

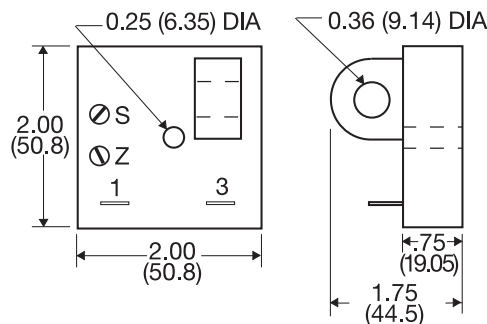

Inches (Millimeters)

AC Current Transducer

DCSA Series

Loop Powered



- Mounts on DIN 1 or DIN 3 Rail
- 0 ... 50 A in 4 Ranges using LCSC10T12 Sensor
- Loop Powered from 10 ... 30 V DC
- Linear Output from 4 ... 20 mA, 1 ... 10 V DC
- Zero and Span Adjustments
- Separate Sensor & Control Unit

Approvals:

Description

The DCSA Series is a loop powered, linear output current transducer that provides an output that is directly proportional to the RMS AC current passing through the LCSC10T12 sensor. The DCSA provides either an analog current or voltage: 4 to 20 mA, 1 to 5 V DC, or 2 to 10 V DC. Each unit is factory calibrated for monitoring (with the LCSC10T12 connected) from 0 to 5, 0 to 10, 0 to 20, or 0 to 50 A in four ranges. Zero and span adjustments allow field calibration if needed. The DCSA mounts on both DIN 1 and DIN 3 rails.

Operation

The DCSA varies the effective resistance of its output in direct proportion to the current flowing in the conductor monitored by the LCSC10T12. Connecting the power supply to terminals C & D provides a 4 to 20 mA DC current. Connect the power supply to terminals C & A to get 1 to 5 V DC at terminal D. Connect the power supply to terminals C & B to get 2 to 10 V DC at terminal D.

Connection

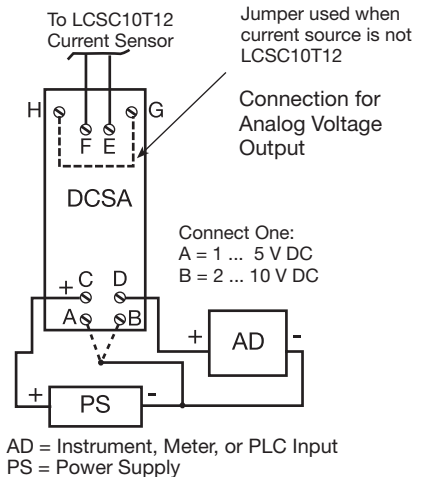
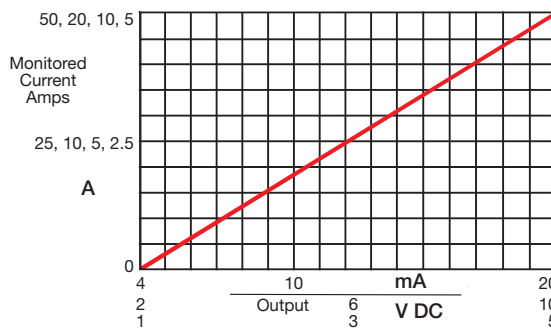
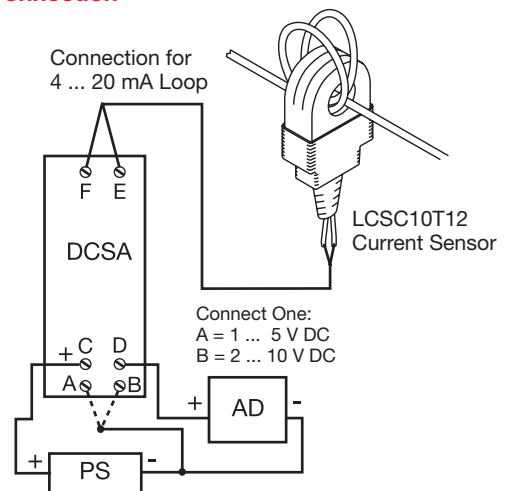

Accessories

Current Sensor
P/N: LCSC10T12



Ordering Table

Current Range with LCSC10T12	DCSA Input Range (F to E)	Part Number
0 ... 5 A	0 ... 5 mA AC	DCSA5
0 ... 10 A	0 ... 10 mA AC	DCSA10
0 ... 20 A	0 ... 20 mA AC	DCSA20
0 ... 50 A	0 ... 50 mA AC	DCSA50
	Toroidal Sensor	LCSC10T12

AC Current Transducer

DCSA Series

Loop Powered

Current
Sensors &
Monitors

Technical Data

DCSA Current Transducer		
Input		
Ranges (without LCSC10T12 connected)	4 factory calibrated ranges in mA AC	0...5 mA, 0...10 mA, 0...20 mA, or 0...50 mA AC
	Factory Calibration	+/-0.5% of full scale
Repeat Accuracy		+/-0.25% of full scale under fixed conditions
Response Time		≅ 300 ms
Temperature Coefficient		+/-0.05%/°C
Input To Output		Not isolated
Output		
Type: Analog		Current directly proportional to input current
Range		4 ... 20 mA; or 1 ... 5 V DC or 2 ... 10 VDC
Supply Voltage*		10 ... 30 V DC
Momentary Voltage		40 V DC for 1 m
Zero Adjust		≅ 3.75 ... 4.25 mA
Span Adjust		18 mA ... 22 mA
Adjustment		Mini-screw, multi-turn potentiometer
Protection		
Dielectric Breakdown		≥ 2500 V RMS terminals to mounting surface
Insulation Resistance		≥ 100 MΩ
Polarity		Units are reverse polarity protected
Mechanical		
Mounting		DIN 1 & DIN 3 rail mounting
Termination	Wire clamp	For 22 ... 14 AWG (.336 mm ² ... 2.5 mm ²)
Environmental		
Operating Temperature		-30°C ... +60°C
Storage Temperature		-40°C ... +85°C
Humidity		95% relative, non-condensing
Weight	DCSA	≅ 1.6 oz (45.4 g)
Accessory		
LCSC10T12 Toroidal Sensor		
Number of Turns		1000
Nominal Output Current Full Range		0 ... 50 mA
Maximum Allowable Current		Steady – 50 A turns Inrush – 300 A turns for 10 s
Burden		≤ 0.5 VA
Frequency	0 ... 20A / 21 ... 50A	20 ... 100 Hz / 30 ... 100 Hz
Sensor Hole		0.36 in. (9.14 mm) for up to #4 AWG (21.1 mm ²) THHN wire
Weight	LCS	≅ 1 oz (28.3 g)

*Minimum loop power supply voltage equals the minimum sensor voltage 10 V DC plus the voltage drop developed across all the other loop devices at 20 mA.

8

Mechanical View

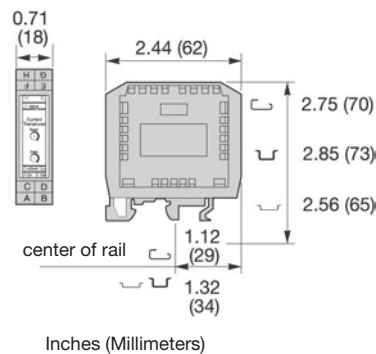

DCSA2B01 06.21.04

AC Current Indicator LCS10T12 & LPM Go-Glow Indicator



- Low Cost Go/No Go Indication
- May Be Connected To Wires Up To 500 Feet (152.4 m) Long
- Remote Monitoring of Currents Up To 50 A
- Green or Red LED Indicator Available

Approvals:

Description

The LCS10T12 connected to the LPM12 or LPMG12 indicator is a low cost, easy to use, go/no go indication system for the remote monitoring of current flow. The LCS10T12 is installed on an adequately insulated wire of the monitored load. Its 12 in. (30.4 cm) leads are connected to the LPM12 or LPMG12 panel mount indicator directly or via customer supplied wires up to 500 feet (152.4 m) long.

Connection

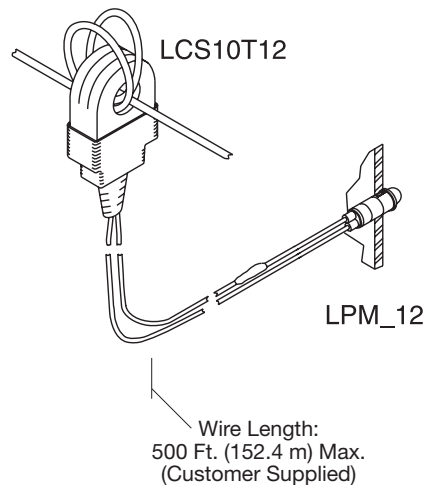

Operation

When the monitored current is 5 ampere-turns, the panel mount LPM indicator will glow. The LCS10T12 is designed to maximize the light output of the panel mount indicator. It can be used to monitor current flow of less than 5 A by passing the monitored conductor 2 or more times through the sensor.

Mechanical View

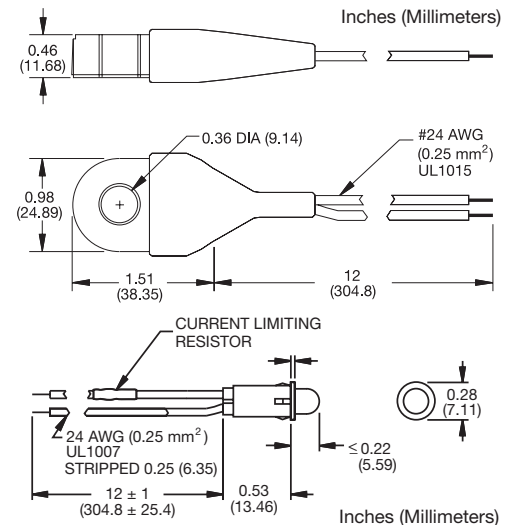

Panel mount indicator designed to match the output of the LCS10T12. The LPM12 and LPMG12 come with 12 in. (30.4 cm) wires and a one piece mounting clip. Both devices install quickly in a 0.25 in. (6.35 mm) hole in panels from 0.031 ... 0.062 in. (0.79 ... 1.6 mm) thick.

CAUTION: The LCS10T12 must be connected to the LPM12 or LPMG12 before current flows to prevent damage or a shock hazard. Monitored wires must be properly insulated.

Ordering Table

Description	Part Number
AC Current Sensor	LCS10T12
Red LED Indicator	LPM12
Green LED Indicator	LPMG12

Technical Data

Monitored Current

Current Range	Wire Passes	Min. Current	Max. Current	Max. Inrush	Max. Wire Dia.
2 ... 50 A AC	1	5 A	50 A	120 A	0.355 in. (9.0 mm)
	2	2.5 A	25 A	60 A	0.187 in. (4.7 mm)
	3	1.7 A	16.6 A	40 A	0.15 in. (3.8 mm)
	4	1.3 A	12.5 A	30 A	0.125 in. (3.2 mm)
	5	5/X	50/X	120/X	

Maximum Current 50 ampere-turns continuous

Frequency 50 ... 60 Hz

DC Resistance of Current Limiter 65 Ω

Mechanical

Sensor Hole 0.36 in. (9.14 mm) for up to #4 AWG

(21.1 mm²) THHN wire

Termination 12 in. (30.4 cm) wire leads

Environmental

Operating/Storage Temperature -40°C ... +60°C / -40°C ... +85°C

Weight LCS: ≅ 0.8 oz (23 g)

LPM: ≅ 0.2 oz (6 g)